



cod. 85192I Edition 10/2020

Contenuti

1. GENERAL PRECAUTIONS	2
1.1. Mounting inside a cylinder	2
2. ANALOGS	3
2.1. Installation guideline	3
2.2. Electrical connections (series MK4-A/WPP-A/WPA-A).....	4
2.3. Electrical connections (series WPG-A).....	7
2.4. Electrical connections (series IK4-A/WRP-A/WRA-A/WRG-A)	8
2.5. Electrical connections (series RK-2).....	11
2.6. Electrical connections (series RK-4).....	12
3. SSI.....	13
3.1. Optional cables	13
3.2. Electrical connections (series MK4-S/WPP-S/WPA-S).....	13
3.3. Electrical connections (series IK4-S/WRP-S/WRA-S).....	15
4. CAN ISO 11898.....	16
4.1. Standard installation	16
4.2. Electrical connections (series MK4-C).....	16
4.3. Electrical connections (series IK4-C).....	17
5. PROFIBUS DPV0 IEC61158.....	18
5.1. Electrical connections (series MK4-P / IK4-P).....	18
5.2. Profibus structure and connections	18
5.3. Cable type and transmission speed	19
5.4. Optional cables	19
5.5. Optional accessoires	19
5.6. Optional node number programmer	19
6. IO-LINK V1.1	20
6.1. Standard installation	20
6.2. Electrical connections	20
7. PROTECTION FOR OUTDOOR INSTALLATIONS OF ANALOG SENSORS	21
8. STANDARD REFERENCE.....	22

1. GENERAL PRECAUTIONS

- The transducer must be installed away from sources of magnetic fields, both static and 50 Hz (electric motors, solenoids, etc.).
- If it uses a floating cursor (PCUR039/PCUR202), the assembly support must be made with nonmagnetic material.
- The transducer connection cable must be wired separate from power cables and/or solenoid controls, drives, or remote switches.
- The 24 VDC feed must be dedicated to the transducers or must be drawn directly from the power terminals and as near as possible.
- Since the transducer cursor is a magnet, make sure there are no iron filings or small fragments of magnetic metal near the transducer. This could produce an accumulation of material on the cursor, with consequent sliding problems.
- The cylinder head (in which the threaded hole will be drilled for inserting the transducer) must be made of nonmagnetic material. If not, the residual magnetization caused by drilling the threaded hole must be less than 4 Gauss.
- The system must be used only in accordance with the required protection level.
- The sensor must be protected against accidental knocks and used in accordance with the instrument's ambient characteristics and performance levels.
- The sensors must be powered with non-distributed networks and always at lengths of less than 30 mt.
- In case of outdoor installations, follow the instructions in paragraph 6.

1.1. Mounting inside a cylinder

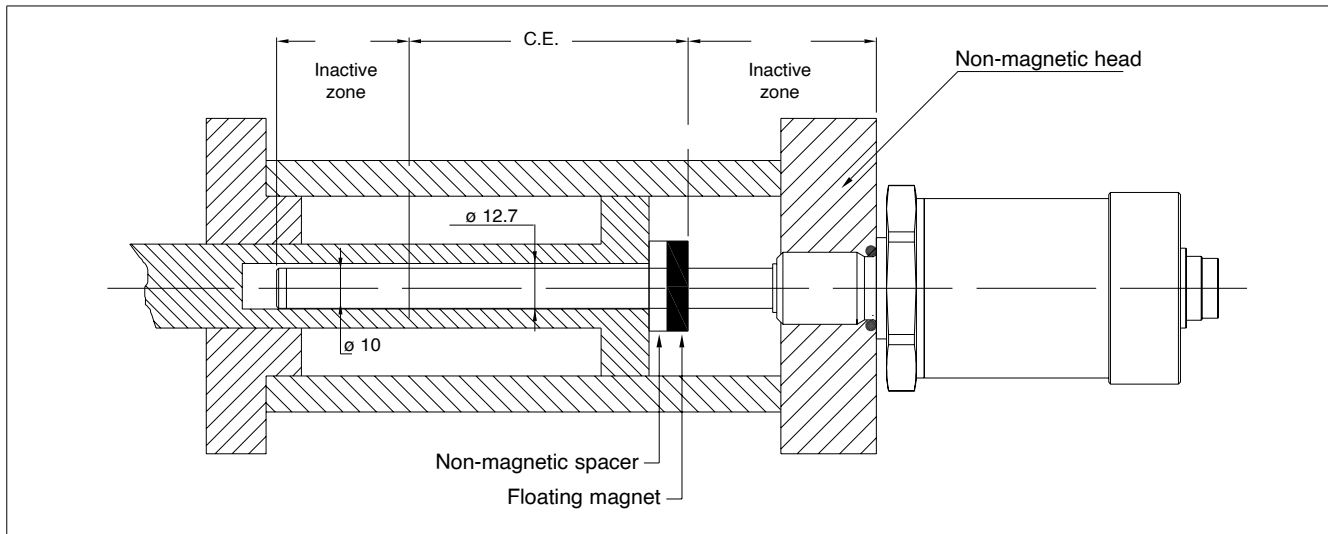

2. ANALOGS

Transducers: WPG-A/MK4-A/WPP-A/WPA-A/WRG-A/WRP-A/WRA-A/RK-4

Outputs: 0...10V, 4...20mA

Installation notes WPG-A/MK4-A/WPP-A/WPA-A

- To guarantee the correct electrical insulation of the transducer from the machine, always assemble the brackets using the plastic washers provided in the package as shown in the fig. a and fig. b.
- The braiding of the shielded transducer connection cable must be connected to the case of the female connector or to the appropriate PIN of screen (WPG-A) so that the shielding is connected to the transducer case.
- The cable shielding on PLC side must be grounded.

In the UL environment the devices must be supplied with a Class 2 Power Supply (as for NEC) or LPS Power Supply (as for EN 60950). If devices are permanently connected to the machine it's requested an external switch or circuit breaker and external overcurrent protection.

2.1. Installation guideline

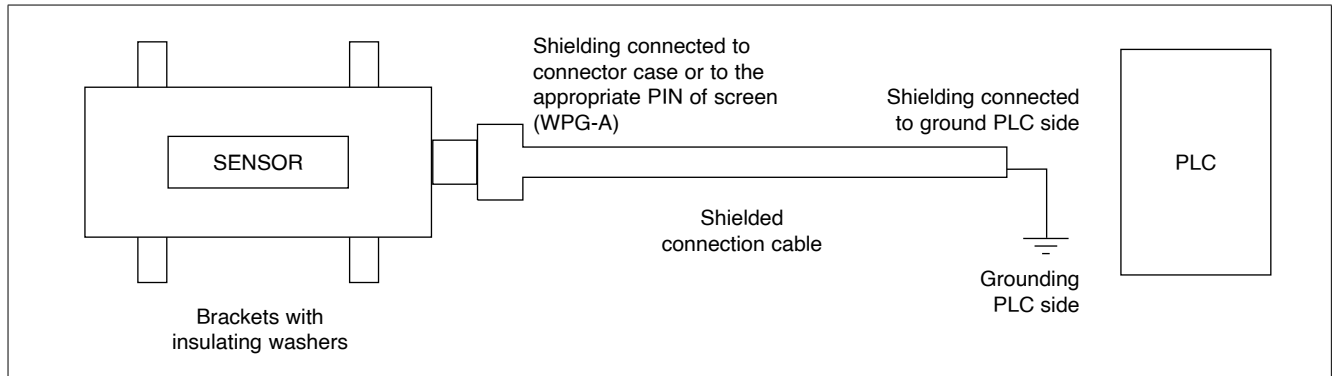

fig. a

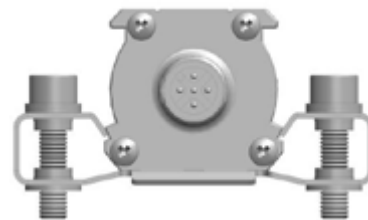
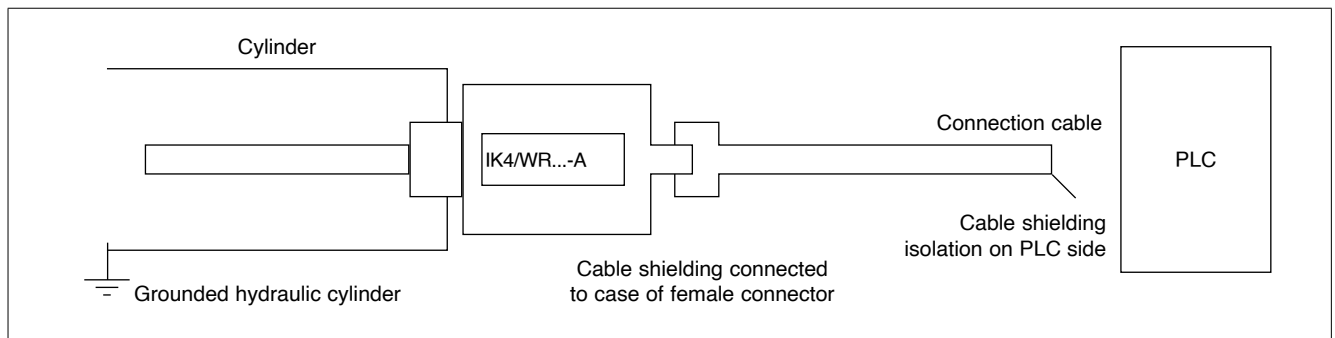

fig. b

Installation notes IK4-A/WRG-A/WRP-A/WRA-A/RK

- The transducer must be on a grounded metallic cylinder.
- The braiding of the shielded transducer connection cable must be connected to the case of the female connector so that the shielding is connected to the transducer case.
- The cable shielding on PLC side must be isolated.

In the UL environment the devices must be supplied with a Class 2 Power Supply (as for NEC) or LPS Power Supply (as for EN 60950). If devices are permanently connected to the machine it's requested an external switch or circuit breaker and external overcurrent protection.



Note:

if the transducer is installed in a cylinder isolated from the ground, the cable shielding on PLC side must be grounded.

2.2. Electrical connections (series MK4-A/WPP-A/WPA-A)

Series MK4-A

OUTPUT MK4-A-A

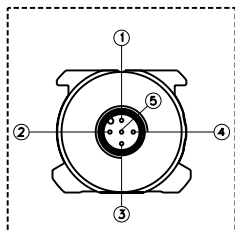

OUTPUT MK4-A-B

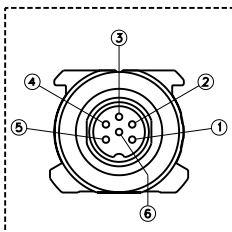

OUTPUT MK4-A-C

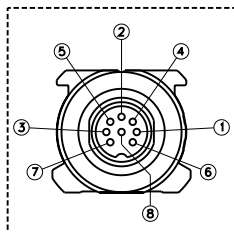

OUTPUT MK4-A-H

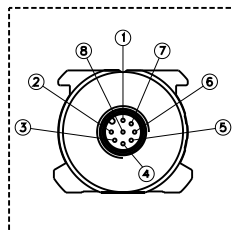

OUTPUT MK4-A-F

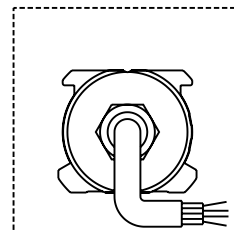

Function	CONNECTORS				CABLES	OPTIONAL CABLES FOR	
	MK4-A-A	MK4-A-B	MK4-A-C	MK4-A-H	MK4-A-F	MK4-A-A	MK4-A-H
	5-pin M12	6-pin M16	8-pin M16	8-pin M12	Standard cable	Pre-assembled 5 pin	Pre-assembled 8 pin
Output cursor 1 0,1...10,1V 0...10V 4...20mA 0...20mA -10...+10V -5...+5V	1	1	5 (1*)	5	Grey	Brown	Green
GND Output cursor 1 (0V)	2	2	2	1	Pink	White	Yellow
Inverse output cursor 1 Output cursor 2 Output speed (not present on W version) 0...10V 4...20mA 0...20mA -10...+10V -5...+5V	3	3	3	3	Yellow	Blue	Pink
GND Output cursor 1 Output cursor 2 Output speed (0V)	2	4	6	2	Pink	White	Grey
Power supply +	5	5	7	7	Brown	Grey	Brown
Power supply GND	4	6	8	6	White	Black	Blue
n.c.	-	-	4	4	-	-	Red
n.c.	-	-	1(5*)	8	-	-	White

(*) = for version 4...20mA / 0...20mA

The transducer case must be grounded with the cable sheathing on the control system side only.

Series **WPP-A**

OUTPUT WPP-A-A

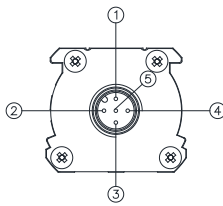

OUTPUT WPP-A-B

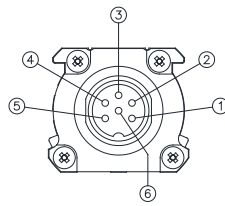

OUTPUT WPP-A-C

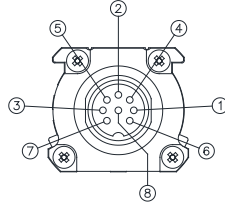

OUTPUT WPP-A-H

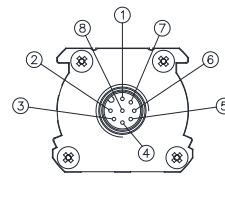

OUTPUT WPP-A-F

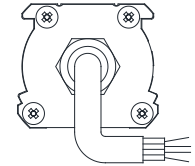

Function	CONNECTORS				CABLES	OPTIONAL CABLES FOR	
	WPP-A-A	WPP-A-B	WPP-A-C	WPP-A-H	WPP-A-F	WPP-A-A	WPP-A-H
	5 pin M12	6 pin M16	8 pin M16	8 pin M12	Standard cable	Pre-assembled 5 pin	Pre-assembled 8 pin
Output cursor 1 0...10V 4...20mA 0...20mA	1	1	5 (1*)	5	Grey	Brown	Green
GND Output cursor 1 (0V)	2	2	2	1	Pink	White	Yellow
Inverse output cursor 1 Output cursor 2 Output speed 0...10V 4...20mA 0...20mA	3	3	3	3	Yellow	Blue	Pink
GND Output cursor 1 Output cursor 2 Output speed (0V)	2	4	6	2	Pink	White	Grey
Power supply+	5	5	7	7	Brown	Grey	Brown
Power supply GND	4	6	8	6	White	Black	Blue
n.c.	-	-	4	4	-	-	Red
n.c.	-	-	1(5*)	8	-	-	White

(*) = for version 4...20mA / 0...20mA

The transducer case must be grounded with the cable sheathing on the control system side only.

Series **WPA-A**

OUTPUT WPA-A-A

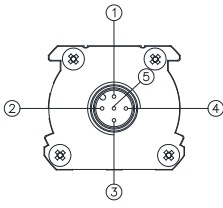

OUTPUT WPA-A-B

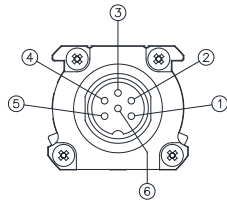

OUTPUT WPA-A-C

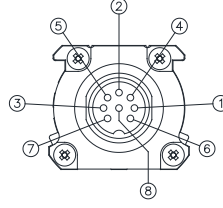

OUTPUT WPA-A-H

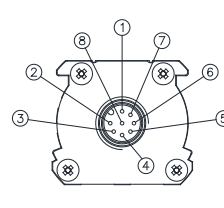

OUTPUT WPA-A-F/R

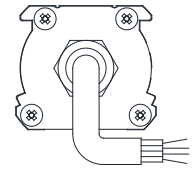

Function	CONNECTORS				CABLES	OPTIONAL CABLES FOR	
	WPA-A-A	WPA-A-B	WPA-A-C(***)	WPA-A-H	WPA-A-F/R	WPA-A-A	WPA-A-H
	5 pin M12	6 pin M16	8 pin M16	8 pin M12	Standard cable	Pre-assembled 5 pin	Pre-assembled 8 pin
Output cursor 1 0...10V 4...20mA 0...20mA	1	1	5 (1*)	5	Grey	Brown	Green
GND Output cursor 1 (0V)	2	2	2	1	Pink	White	Yellow
Inverse output cursor 1 Output cursor 2 Output speed 0...10V 4...20mA 0...20mA	3	3	3	3	Yellow	Blue	Pink
GND Output cursor 1 Output cursor 2 Output speed (0V)	2	4	6	2	Pink	White	Grey
Power supply+	5	5	7	7	Brown	Grey	Brown
Power supply GND	4	6	8	6	White	Black	Blue
n.c.	-	-	4	4	-	-	Red
n.c.	-	-	1(5*)	8	-	-	White
Temperature ratings	-25+80 °C	-30+85 °C	-30+85 °C	-30+85 °C	-30+80 °C / -30+75 °C	-25+80 °C	-25+80 °C

(*) = for version 4...20mA / 0...20mA

(**) The operating temperature ranges, except where expressly indicated, are also applicable in the UL scope.

The transducer case must be grounded with the cable sheathing on the control system side only.

(***) Not available with UL certification.

2.3. Electrical connections (series WPG-A)

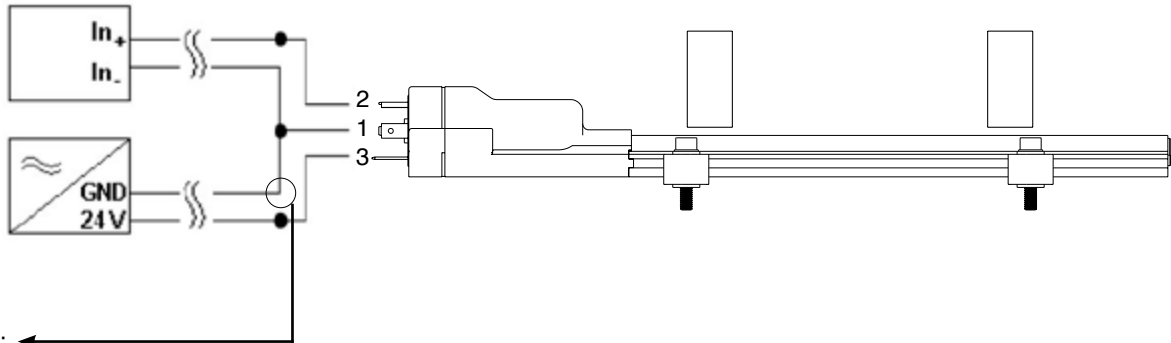
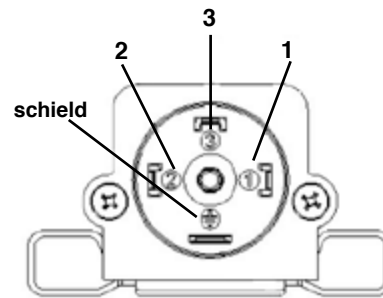

Series WPG-A

PIN	FUNCTION
1	Power supply -
2	Output
3	Power supply +
	Cable Shield (must be connected to the panel side, too)

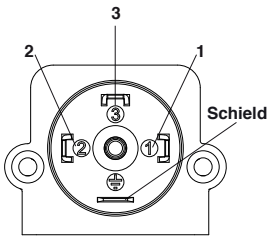
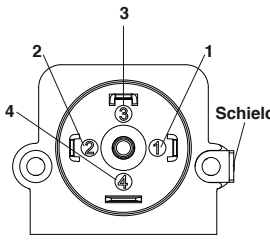
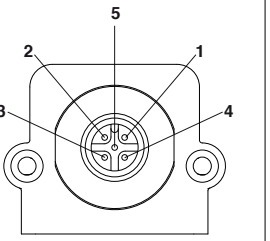
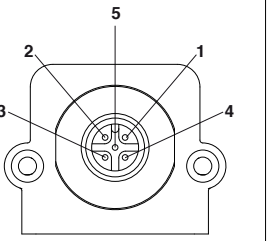

Note:  Make a connection as close as possible to transducer

Series WPG-A

					
		WPG-A-M-(N/W/E/M/R/S)	WPG-A-M-(J/Q/Z)	WPG-A-A-(N/W/E/M/R/S)	WPG-A-A-(J/Q/Z)
PIN		Valve single output	Valve double output	5 pin M12 single output	5 pin M12 double output
1	Power supply -	Power supply -	Power supply -	Direct output	Direct output
2	Direct output	Direct output	Direct output	GND output	GND output
3	Power supply +	Power supply +	Power supply +	n.d.	Reverse output
4	Shield	Shield	Reverse output	Power supply -	Power supply -
5				Power supply +	Power supply +
			Shield	Connector body	Connector body

2.4. Electrical connections (series IK4-A/WRP-A/WRA-A/WRG-A)

Series IK4-A / WRG-A

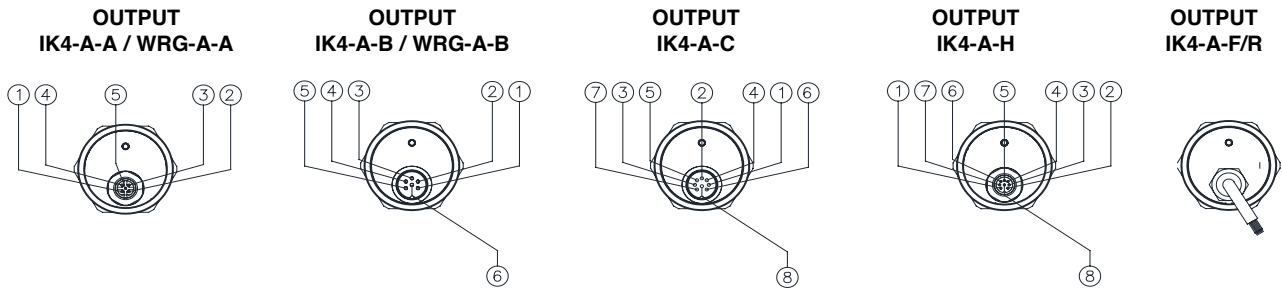

Function	CONNECTORS				CABLES	OPTIONAL CABLES	
	IK4-A-A / WRG-A-A	IK4-A-B / WRG-A-B	IK4-A-C	IK4-A-H	IK4-A-F/R	CAV00_	CAV01_ /CAV02_
	5 pin M12	6 pin M16	8 pin M16	8 pin M12	Standard cables	Pre-assembled cable 8 pin IK4A-H	Pre-assembled cable 5 pin IK4A-A
Output 1 (position) 0...10V 4...20mA 0...20mA	1	1	5 (1*)	5	Grey	Green	Brown
GND Output 1 (0V)	2	2	2	1	Pink	Yellow	White
Output 2 (inverse position) 10...0V 20...4mA 20...0mA	3	3	3	3	Yellow	Pink	Blue
GND Output 2 (0V)	2	4	6	2	Green	Grey	White
Power supply +	5	5	7	7	Brown	Brown	Grey
Power supply GND	4	6	8	6	White	Blue	Black
n.c.	-	-	4	4	-	Red	-
n.c.	-	-	1 (*5)	8	-	White	-

Series WRP-A

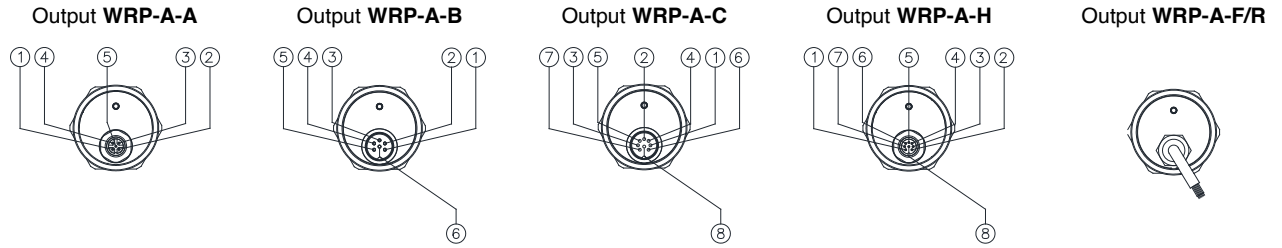

Function	CONNECTORS				CABLES	OPTIONAL CABLES	
	WRP-A-A	WRP-A-B	WRP-A-C	WRP-A-H	WRP-A-F/R	CAV00_	CAV01_/CAV02_
	5 pin M12	6 pin M16	8 pin M16	8 pin M12	Standard cables	Pre-assembled cable 8 pin WRP-A-H	Pre-assembled cable 5 pin WRP-A-A
Output 1 (position) 0...10V 4...20mA 0...20mA	1	1	5 (1*)	5	Grey	Green	Brown
GND Output 1 (0V)	2	2	2	1	Pink	Yellow	White
Output 2 (inverse position) 10...0V 20...4mA 20...0mA	3	3	3	3	Yellow	Pink	Blue
GND Output 2 (0V)	2	4	6	2	Green	Grey	White
Power supply +	5	5	7	7	Brown	Brown	Grey
Power supply GND	4	6	8	6	White	Blue	Black
n.c.	-	-	4	4	-	Red	-
n.c.	-	-	1 (*5)	8	-	White	-

(*) = for version 4...20mA / 0...20mA

Series WRA-A

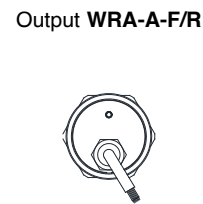
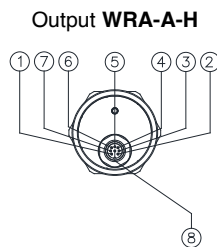
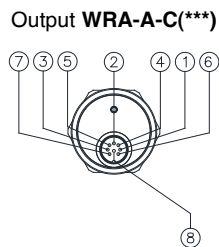
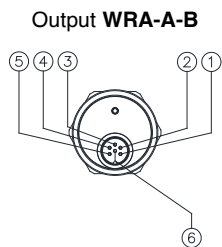
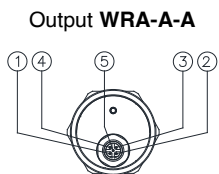

Function	CONNECTORS				CABLES	OPTIONAL CABLES	
	WRA-A-A	WRA-A-B	WRA-A-C	WRA-A-H	WRA-A-F/R	CAV00_	CAV01_/CAV02_
	5 pin M12	6 pin M16	8 pin M16	8 pin M12	Standard cables	Pre-assembled cable 8 pin WRA-A-H	Pre-assembled cable 5 pin WRA-A-A
Output 1 (position) 0...10V 4...20mA 0...20mA	1	1	5 (1*)	5	Grey	Green	Brown
GND Output 1 (0V)	2	2	2	1	Pink	Yellow	White
Output 2 (inverse position) 10...0V 20...4mA 20...0mA	3	3	3	3	Yellow	Pink	Blue
GND Output 2 (0V)	2	4	6	2	Green	Grey	White
Power supply +	5	5	7	7	Brown	Brown	Grey
Power supply GND	4	6	8	6	White	Blue	Black
n.c.	-	-	4	4	-	Red	-
n.c.	-	-	1 (*5)	8	-	White	-
Temperatura ratings **	-25+80 °C	-30+85 °C	-30+85 °C	-30+85 °C	-30+80 °C / -30+75 °C	-25+80 °C	-25+80 °C

(*) = for version 4...20mA / 0...20mA

(**) The operating temperature ranges, except where expressly indicated, are also applicable in the UL scope.

(***) Not available with UL certification.

2.5. Electrical connections (series RK-2)

Series RK-2

Electrical connections (RK - 2 - _____ - S)

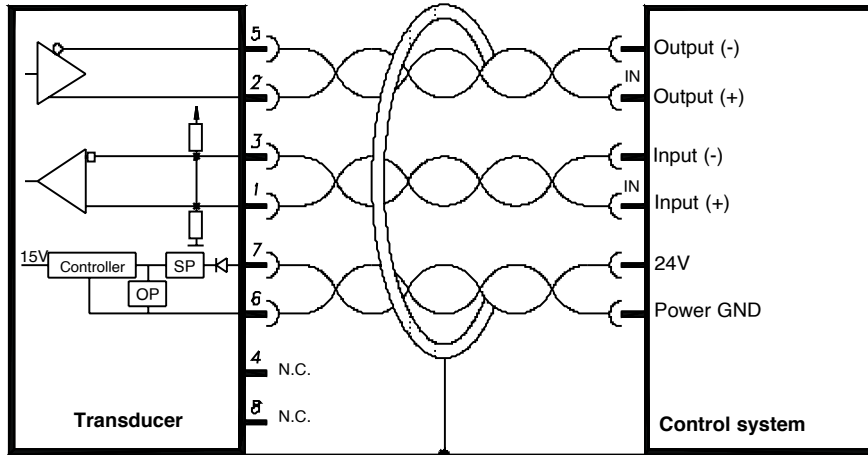

RK- _____ -S	Cable
Output (+)	Gray
Output (-)	Green
Input (+)	Yellow
Input (-)	Pink
Power supply +	Brown
Power supply	
GND	Blue

Electrical connections (RK - 2 - _____ - N / K / E)

RK- _____ -N	RK- _____ -K	RK- _____ -E	Cable
Output 0,1...10,1Vdc	Output 0,1...5,1Vdc	Output 4...20mA	Yellow
Output GND	Output GND	Output GND	Pink
Power supply +	Power supply +	Power supply +	Brown
Power supply GND	Power supply GND	Power supply GND	Blue

2.6. Electrical connections (series RK-4)

Series **RK-4**

Electrical connections (RK - 4 - _____ - S)

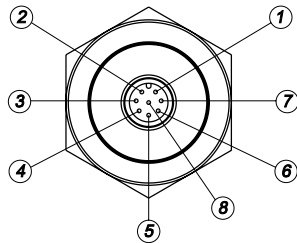
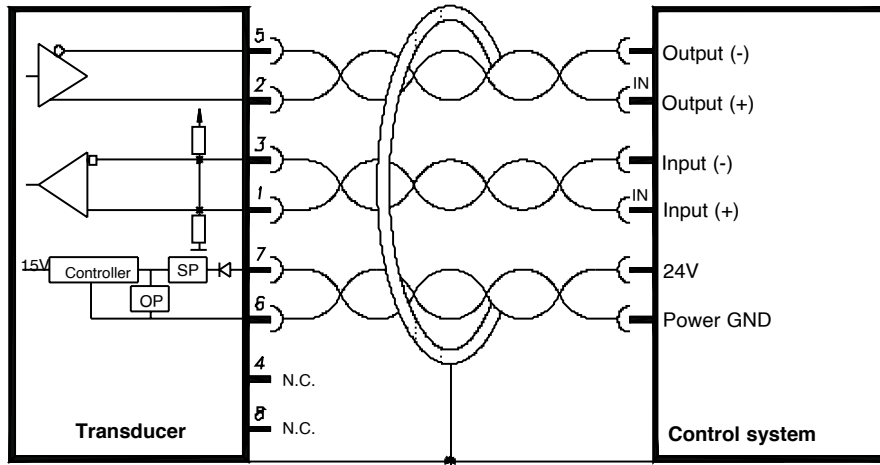

1	Input +
2	Output +
3	Input -
4	n.c.
5	Output -
6	Power supply GND
7	Power supply +
8	n.c.

Electrical connections (RK - 4 - _____ - N / K / E)

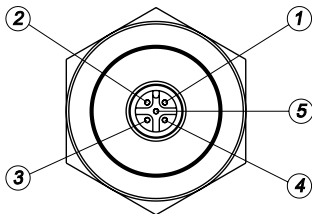

	RK-4-_____ -N	RK-4-_____ -K	RK-4-_____ -E
1	Output 0,1...10,1Vdc	Output 0,1...5,1Vdc	Output 4...20mA
2	Output GND	Output GND	Output GND
3	n.c.	n.c.	n.c.
4	Power supply GND	Power supply GND	Power supply GND
5	Power supply +	Power supply +	Power supply +

3. SSI

Transducers: MK4-S/IK4-S/WPP-S/WPA-S/WRP-S/WRA-S

Outputs: MK4-S/IK4-S/WPP-S/WPA-S/WRP-S/WRA-S

Installation notes

- Connections with instructions taken from MK4-S/WPP-S/WPA-S data-sheet.
- Braiding grounded on PLC side for both MK/WP and IK/WR.
- The braiding must always be wired so that it is electrically connected to the connector case on transducer side.
- Cable length is based on baud rate.

3.1. Optional cables

PRE-ASSEMBLED CABLE WITH STRAIGHT CONNECTOR

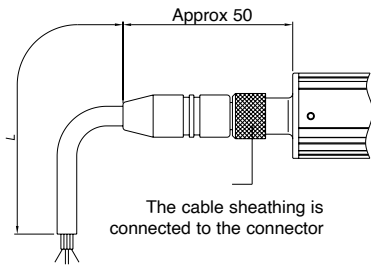

PRE-ASSEMBLED CABLE WITH 90° CONNECTOR

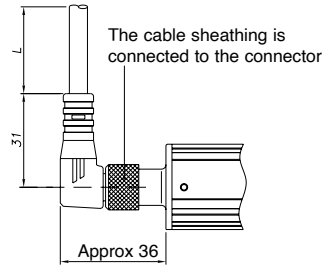

8-pin cable code		MK4-S/WPP-S/WPA-S-H	
Length "L"		CODE	
		Straight cable	Cable to 90°
2	mt	CAV002	CAV005
5	mt	CAV003	CAV006
10	mt	CAV004	CAV007
15	mt	CAV009	CAV008

3.2. Electrical connections (series MK4-S/WPP-S/WPA-S)

Series MK4-S

OUTPUT MK4-S-B

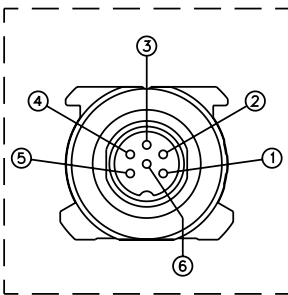

USCITA MK4-S-C

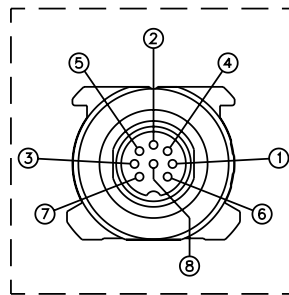

USCITA MK4-S-H

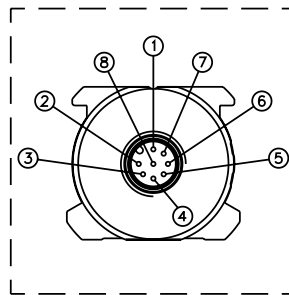

USCITA MK4-S-F/R

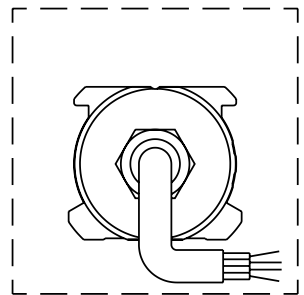

Function	MK4-S-B	MK4-S-C	MK4-S-H	MK4-S-F	MK4-S-R	CAV00X
	6-pin M16	8-pin M16	8-pin M12	Cable output	PUR cable output	Optional 8-pin cable
Data -	1	5	5	Orange	White	Green
Data +	2	2	2	Orange / White	Blue	Gray
Clock +	3	1	3	Green / White	Gray	Pink
Clock -	4	3	1	Green	Yellow	Yellow
Power supply +	5	7	7	Blue / White	Green	Brown
Power supply GND	6	6	6	Blue	Brown	Blue
n.c.	-	8	8	-	Pink	White
n.c.	-	4	4	-	-	Red

The transducer case must be grounded with the cable sheathing on the control system side only

Series WPP-S

OUTPUT WPP-S-B

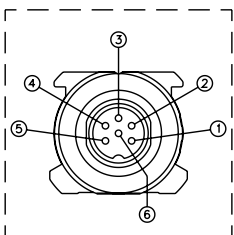

OUTPUT WPP-S-C

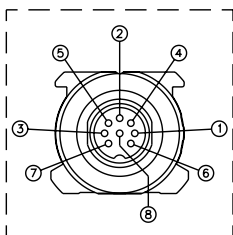

OUTPUT WPP-S-D

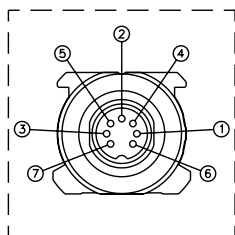

OUTPUT WPP-S-H

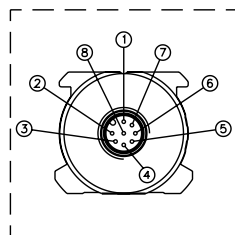

OUTPUT WPP-S-F/R

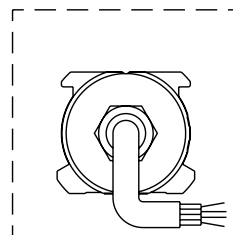

Function	WPP-S-B	WPP-S-C	WPP-S-D	WPP-S-H	WPP-S-F	WPP-S-R	CAV00X
	6-pin M16	8-pin M16	7-pin M16	8-pin M12	Cable output	PUR cable output	Optional 8-pin cable
Data -	1	5	1	5	Orange	Pink	Green
Data +	2	2	2	2	Orange / White	Blue	Gray
Clock +	3	1	3	3	Green / White	Gray	Pink
Clock -	4	3	4	1	Green	Yellow	Yellow
Power supply +	5	7	5	7	Blue / White	Green	Brown
Power supply GND	6	6	6	6	Blue	Brown	Blue
n.c.	-	8	7	8	-	-	White
n.c.	-	4	-	4	-	-	Red

The transducer case must be grounded with the cable sheathing on the control system side only.

Series WPA-S

OUTPUT WPA-S-B

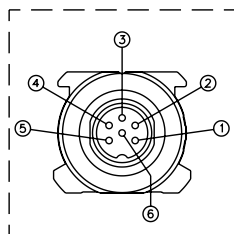

OUTPUT WPA-S-C

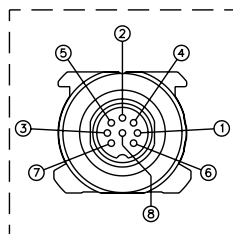

OUTPUT WPA-S-D

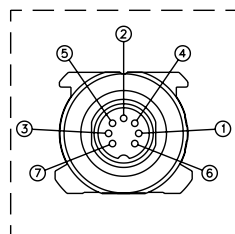

OUTPUT WPA-S-H

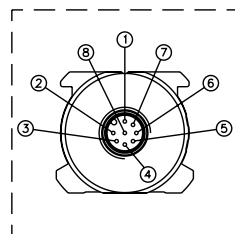

OUTPUT WPA-S-F/R

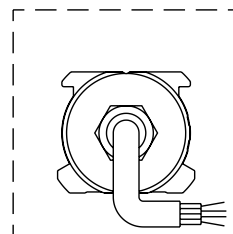

Function	WPA-S-B	WPA-S-C	WPA-S-D	WPA-S-H	WPA-S-F	WPA-S-R	CAV00X
	6-pin M16	8-pin M16	7-pin M16	8-pin M12	Cable output	PUR cable output	Optional 8-pin cable
Data -	1	5	1	5	Orange	Pink	Green
Data +	2	2	2	2	Orange / White	Blue	Gray
Clock +	3	1	3	3	Green / White	Gray	Pink
Clock -	4	3	4	1	Green	Yellow	Yellow
Power supply +	5	7	5	7	Blue / White	Green	Brown
Power supply GND	6	6	6	6	Blue	Brown	Blue
n.c.	-	8	7	8	-	-	White
n.c.	-	4	-	4	-	-	Red

The transducer case must be grounded with the cable sheathing on the control system side only.

3.3. Electrical connections (series IK4-S/WRP-S/WRA-S)

Series IK4-S

Function	IK4-S-B <i>6-pin M16</i>	IK4-S-F <i>Cable output</i>	IK4-S-R <i>PUR cable output</i>
Data -	1	Orange	Pink
Data +	2	Orange / White	Blue
Clock +	3	Green / White	Gray
Clock -	4	Green	Yellow
Power supply +	5	Blue / White	Green
Power supply GND	6	Blue	Brown
n.c.	-	-	-
n.c.	-	-	-

OUTPUT IK4-S-B

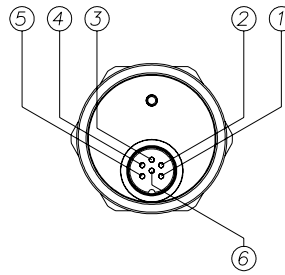

OUTPUT IK4-S-F/R

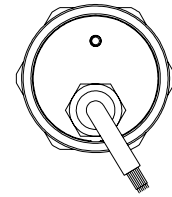

Series WRP-S

OUTPUT WRP-S-B

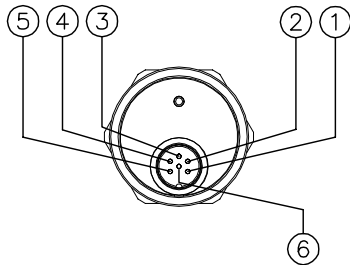

OUTPUT WRP-S-D

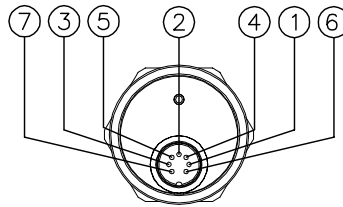

OUTPUT WRP-S-F/R



Function	WRP-S-B	WRP-S-D	WRP-S-F	WRP-S-R
	<i>6-pin M16</i>	<i>7-pin M16</i>	<i>Cable output</i>	<i>PUR cable output</i>
Data -	1	1	Orange	Pink
Data +	2	2	Orange / White	Blue
Clock +	3	3	Green / White	Gray
Clock -	4	4	Green	Yellow
Power supply +	5	5	Blue / White	Green
Power supply GND	6	6	Blue	Brown
n.c.	-	7	-	-
n.c.	-	-	-	-

Serie WRA-S

OUTPUT WRA-S-B

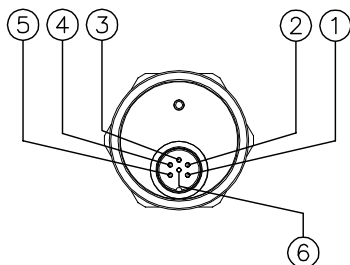

OUTPUT WRA-S-D

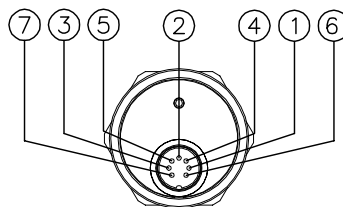

OUTPUT WRA-S-F/R

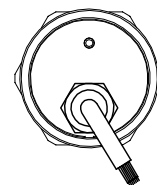

Function	WRA-S-B	WRA-S-D	WRA-S-F	WRA-S-R
	<i>6-pin M16</i>	<i>7-pin M16</i>	<i>Cable output</i>	<i>PUR cable output</i>
Data -	1	1	Orange	Pink
Data +	2	2	Orange / White	Blue
Clock +	3	3	Green / White	Gray
Clock -	4	4	Green	Yellow
Power supply +	5	5	Blue / White	Green
Power supply GND	6	6	Blue	Brown
n.c.	-	7	-	-
n.c.	-	-	-	-

Transducers: MK4-C / IK4-C

Outputs: CANopen DP406

Installation notes

- Make sure that the transducer body is electrically connected to the machine body (ground).
- If a shielded, prewired cable was not purchased, make sure to connect the braiding (shielding) of the cable to the body of the mobile female connector.
- DO NOT connect the power supply GND to earth or to the cable shielding.
- Connect the cable shielding only on transducer side and not on power supply side.
- Make sure that there is a terminator plug (120Ω resistor between CANH and CANL lines) at the beginning and end of the network.

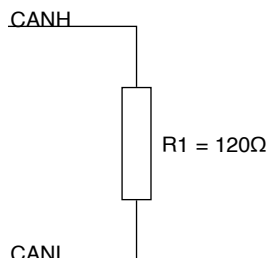

- For inside cylinder applications, make sure that the cylinder head is not magnetized.

4.1. Standard installation

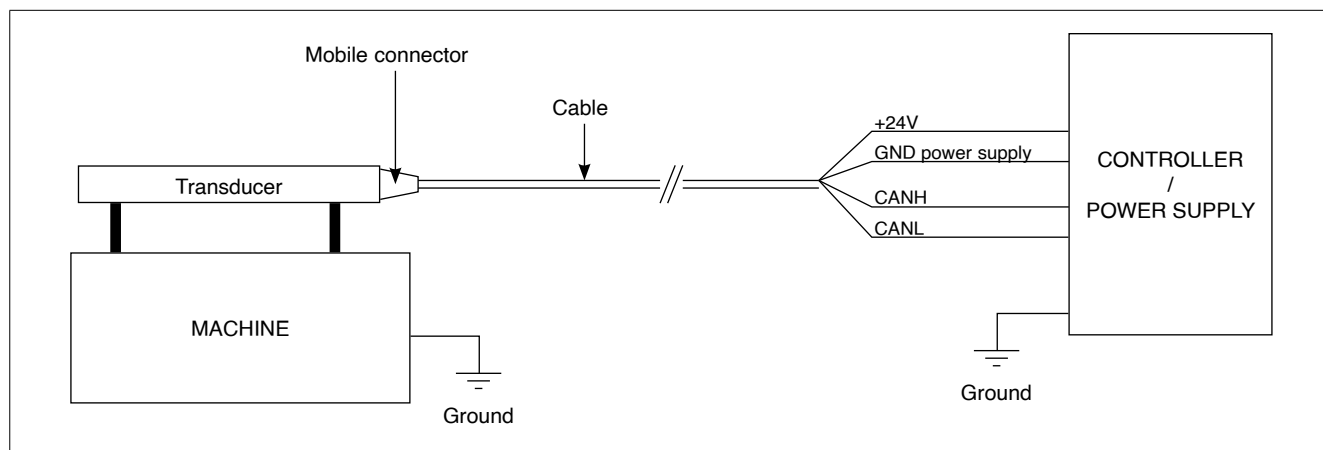

4.2. Electrical connections (series MK4-C)

Series MK4-C

OUTPUT MK4-C-A

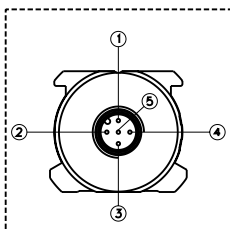

OUTPUT MK4-C-B

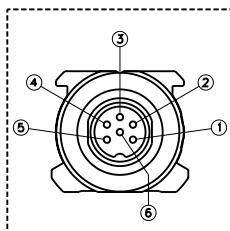

OUTPUT MK4-C-F

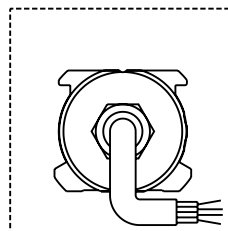

Function	Connector (B) Pin°	Connector (A) Pin°	Cable (Wire color)
CAN L	1	5	Blue
CAN H	2	4	White
n.c.	3	1	-
n.c.	4	-	-
Power + Vdc	5	2	Red
GND power supply	6	3	Black

ATTENTION ! Do not connect the GND to the ground or to the cable sheathing

4.3. Electrical connections (series IK4-C)

Serie IK4-C

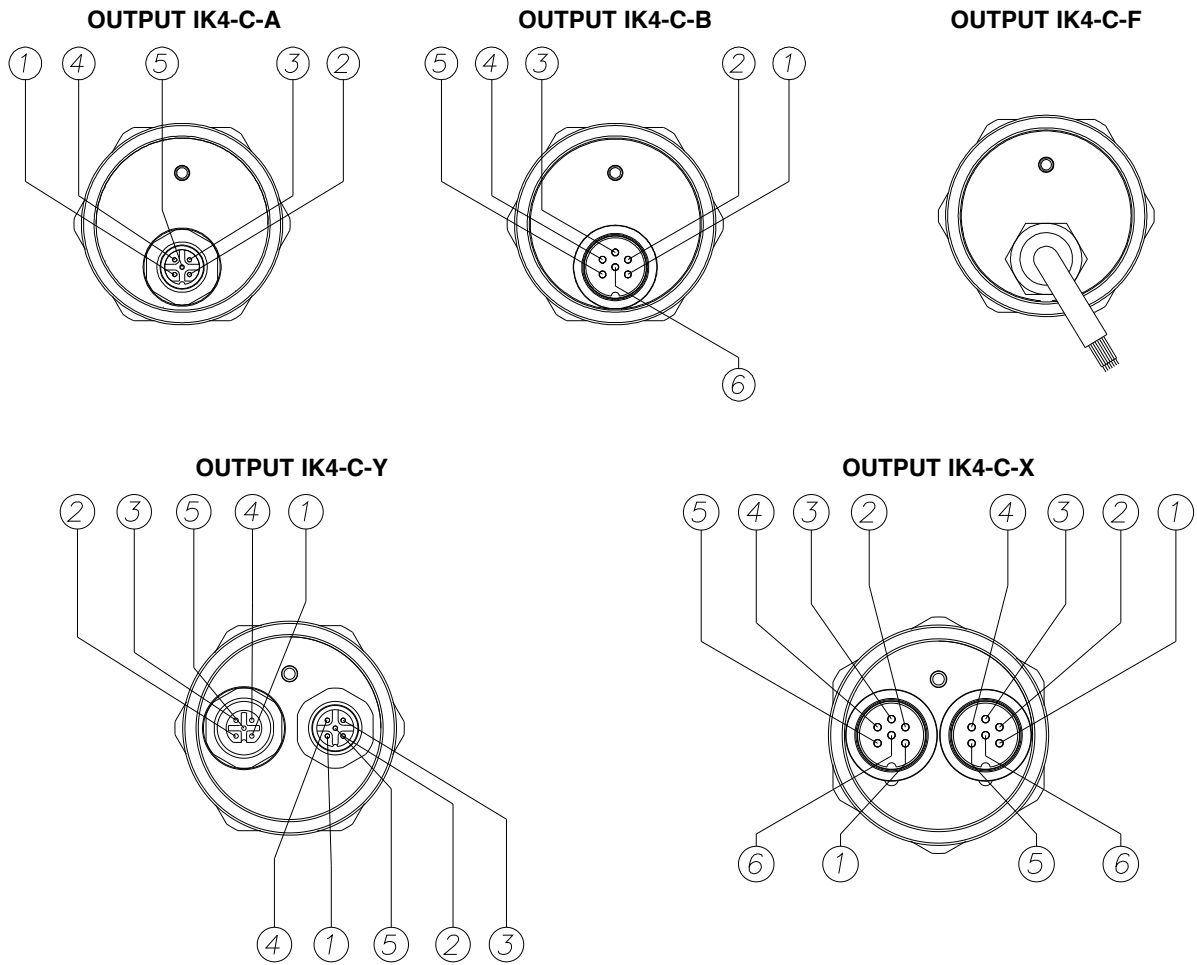

Function	CONNECTORS						CABLE
	IK4-C-A	IK4-C-B	IK4-C-Y		IK4-C-X		IK4-C-F
	5-pin M12	6-pin M16	Double connector 5-pin M12 (male + female)		Double connector 6-pin M16 (male + female)		Standard cable 4-pin
		male	female	male 1	male 2		
CAN L	5	1	5	5	1	1	BLUE
CAN H	4	2	4	4	2	2	WHITE
CAN GND (n.c.)	1	3	1	1	3	3	-
n.c.	-	4	-	-	4	4	-
Power supply +	2	5	2	2	5	5	RED
Power supply GND	3	6	3	3	6	6	BLACK

5. PROFIBUS DPV0 IEC61158

Transducers: MK4-P / IK4-P

Installation notes

- Connections with the information obtained from the datasheet dell'MK4-P and IK4-P
- Braiding grounded on PLC side for both MK and IK.
- The braiding must always be wired so that it is electrically connected to the connector case on transducer side.
- Cable length is based on baud rate.

5.1. Electrical connections (series MK4-P / IK4-P)

OUTPUT MK4PW/IK4PW

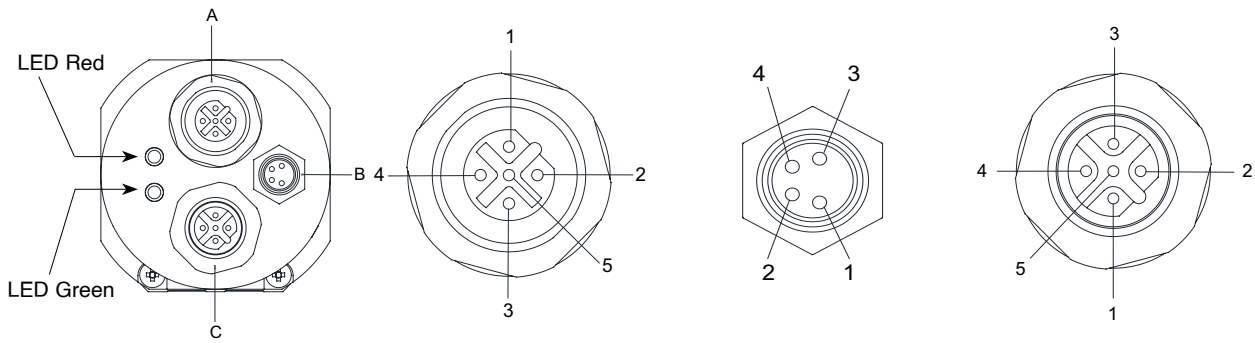

CONNECTOR A (M12 female)	
1	5VD_ISO
2	LINE_A/N
3	GND_ISO
4	LINE_B/P
5	GROUND

CONNECTOR B (M8 male)	
1	24V
2	N.C.
3	0V
4	N.C.
5	GROUND

CONNECTOR C (M12 male)	
1	5VD_ISO
2	LINE_A/N
3	GND_ISO
4	LINE_B/P
5	GROUND

5.2. Profibus structure and connections

A Profibus network lets you connect peripheral Slave devices (transducers or actuators) to Class 1 Master central control units (typically PLCs). The network software is installed with a Class 2 Master containing a database with the GSD files of all connected devices. The network is designed and parameterized with a graphics tool, then the configuration is downloaded to the Class 1 Masters in the network. The Class 1 Master(s) start(s) the communication process with the peripheral devices according to the configuration received from the Class 2 Master.

This process includes an initial data exchange regarding Slave identification, parameterization, and configuration.

When this phase is done, application management begins with exchange of process data on the network.

The GSD file contains all information on device identification, supported functions, and length/format of data packets.

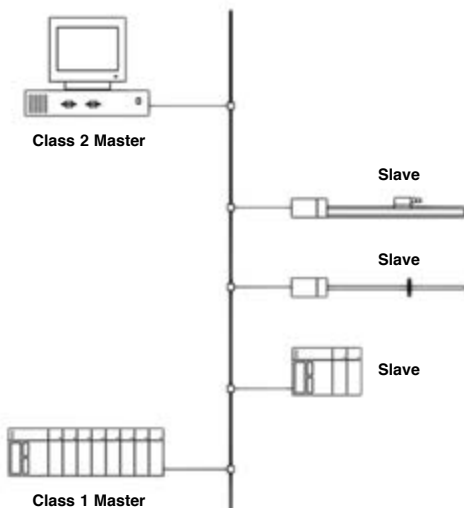

Connection with two M12 connectors + 1 M8 connector:

- no T connection required
- standard M12 and M8 connectors
- separate power supply line (ideal for use of programmer)
- for power supply: use a shielded cable with metal connector and shield connected to connector case

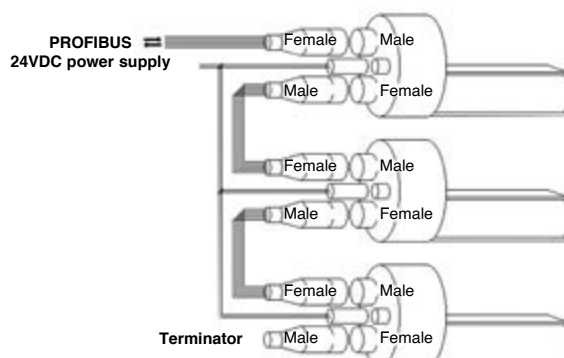

5.3. Cable type and transmission speed

The cables must have the following characteristics:

Parameter		Cable Type A
Impedance	ohm	135...165
Capacity	pF/m	< 30
Loop resistance	ohm/km	< 110
Section of the core	mm ²	> 0.34 (AWG 22/1)

With this type of cable lengths to reach a bus segment, depending on the speed are:

Transfer Rate	kbit/s	9.6	31.25	45.45	93.75	187.5	500	1500	3000	6000	12000
Cable length	mm	1200	1200	1200	1000	1000	400	200	100	100	100

5.4. Optional cables

M8 4-pin axial female connector, pre-wired with 3-meter cable for power supply	PCAV700
M8 4-pin axial female connector, pre-wired with 5-meter cable for power supply	PCAV701
M12 5-pin axial female connector, pre-wired with 3-meter cable for communication	PCAV702
M12 5-pin axial female connector, pre-wired with 5-meter cable for communication	PCAV704
M12 5-pin axial male connector, pre-wired with 3-meter cable for communication	PCAV703
M12 5-pin axial male connector, pre-wired with 5-meter cable for communication	PCAV705

5.5. Optional accessories

Profibus terminator (axial M12 male connector)	CON049
Pre-assembled cable with M12 5pin straight male connector	CON380
Pre-assembled cable with M12 5pin straight female connector	CON390
Node number programmer	PNP-1
Downloadable GSD file from the website www.gefran.com	

5.6. Optional node number programmer

The PNP-1 node number programmer lets you read and set the node number on a Profibus network for MK4-P and IK4-P series sensors.

This accessory component is used if you do not have a Class 2 Master programmer.

See the PNP-1 programmer technical sheet and manual for detailed information.



6. IO-LINK V1.1

Transducers: WPL

For IO-Link application use a not shielded cable as defined by the IO-Link standard.

1. Typical installation (recommended)

A: Sensor

B: Connection cable

C: Shield grounded on the PLC side/Master IO-Link

D: PLC/Master IO-Link

2. To guarantee correct electrical transducer insulation from the machine system, always assemble the brackets using the plastic bushings provided in the package as per the diagram in fig. a and b.

6.1. Standard installation

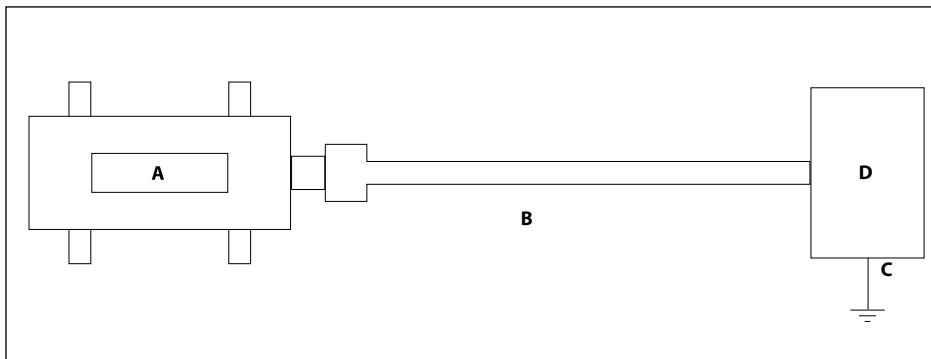

fig. a.

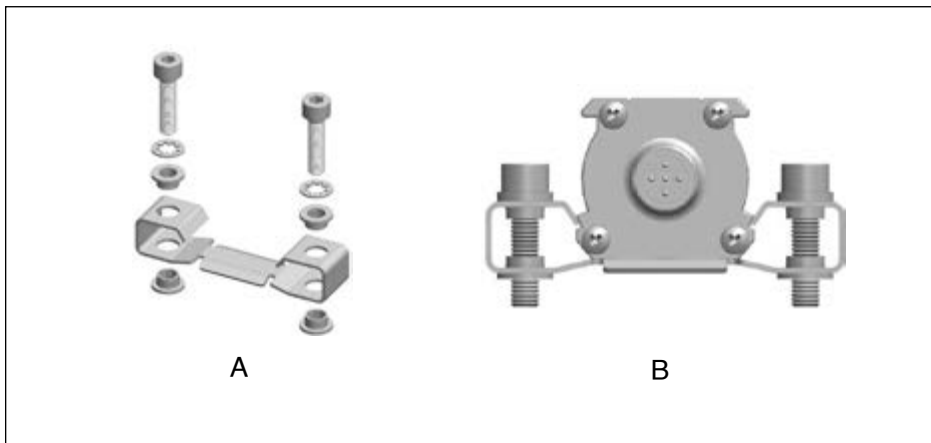

fig. b.

6.2. Electrical connections

5 pin M12x1 connector	M12x1 5 pin Connector	IO-LINK Output
	1	V+
	2	DO (*)
	3	V-
	4	IO-Link
	5	N.C.

7. PROTECTION FOR OUTDOOR INSTALLATIONS OF ANALOG SENSORS

Analog magnetostrictive WPG/MK4/WPP/WPA/IK4/WRG/WRP/WRA voltage current output

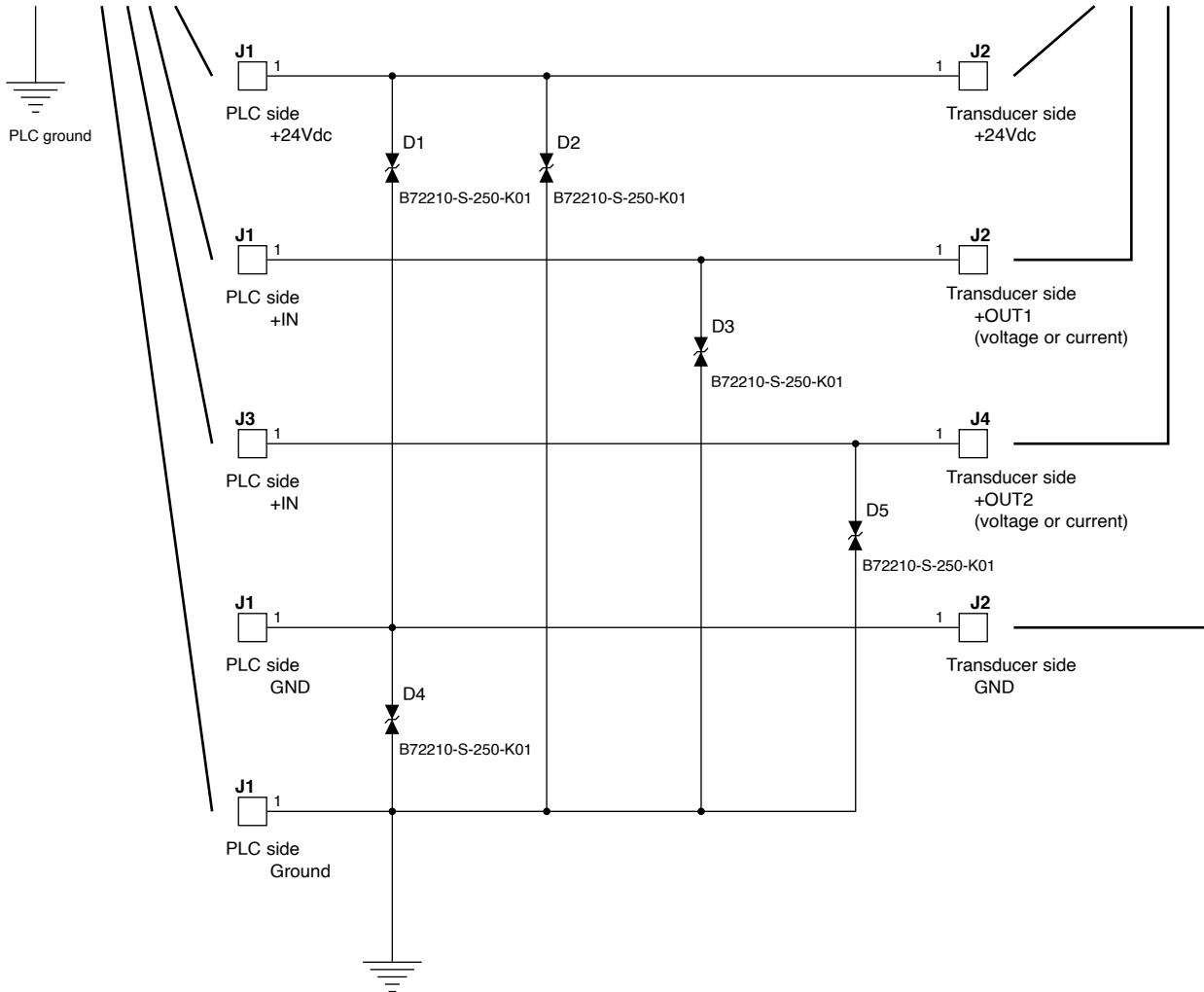
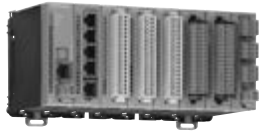

8. STANDARD REFERENCE

Gefran products, described in this manual, are compliant to the European Directive 2014/30/EU.

They are tested according to the standard EN 61326-1 "Electrical equipment for measurement, control and laboratory use - EMC requirements", Part 1 "general requirements and EN 61326-2-3 "Electrical equipment for measurement, control and laboratory use - EMC requirements", Part 2-3: Particular requirements - Test configuration, operational conditions and performance criteria for transducers with integrated or remote signal conditioning.

Electromagnetic Compatibility (EMC) requirements are classified in two types: Emission requirements, Immunity requirements

Emission requirements

For class B equipment the limits, the measuring methods and the provisions given in CISPR11, EN 61000-3-2 and EN 61000-3-3 apply.

Equipment classification and choice of respective limits shall be determined after taking into account the intended environment and emission requirement in the areas of use

Immunity requirements

The immunity test requirements are given table 1 for ONDA and table 2 for HYPERWAVE.

The tests shall be conducted in accordance with the basic standards. The tests shall be carried out one at time.

Table 1. Requirements for immunity testing for devices used in industrial environments (ONDA technology)

Port	Test	Basic standard	Value required by the standard	Value obtained by ONDA	Performance required by the standard	Performance obtained by ONDA
Enclosure	Electrostatic discharge (ESD)	EN 61000-4-2	4/8 kV contact/air	4/8 kV contact/air	B	A
	EM field	EN 61000-4-3	10 V/m (from 80 MHz to 1 GHz) 3V/m (from 1,4 GHz to 2 GHz) 1 V/m (from 2,0 GHz to 2,7 GHz)	10 V/m (from 80 MHz to 1 GHz) 3V/m (from 1,4 GHz to 2 GHz) 1 V/m (from 2,0 GHz to 2,7 GHz)	A	A
	Magnetic field	EN 61000-4-8	30 A/m	400 A/m	A	A
Power supply V DC	Burst	EN 61000-4-4	2 kV (5/50 ns, 5 kHz)	2 kV (5/50 ns, 5 kHz)	B	A
	Surge	EN 61000-4-5	1 kV/ 2kV	1 kV/ 2kV	B	B
	Conducted RF	EN 61000-4-6	3 V/m (from 150 kHz to 80 MHz)	10 V/m (from 150 kHz to 80 MHz)	A	A
I/O signal/ control (including functional earth lines)	Burst	EN 61000-4-4	1 kV (5/50 ns, 5 kHz)	2 kV (5/50 ns, 5 kHz)	B	A
	Surge	EN 61000-4-5	1 kV	1 kV	B	B
	Conducted RF	EN 61000-4-6	3 V (from 150 kHz to 80 MHz)	10 V/m (from 150 kHz to 80 MHz)	A	A

Table 2. Requirements for immunity testing for devices used in industrial environments (HYPERWAVE technology)

Port	Test	Basic standard	Value required by the standard	Value obtained by HYPERWAVE	Performance required by the standard	Performance obtained by HYPERWAVE
Enclosure	Electrostatic discharge (ESD)	EN 61000-4-2	4/8 kV contact/air	16/8 kV contact/air	B	A
	EM field	EN 61000-4-3	10 V/m (from 80 MHz to 1 GHz) 3V/m (from 1,4 GHz to 2 GHz) 1 V/m (from 2,0 GHz to 2,7 GHz)	10 V/m (from 80 MHz to 2,7 GHz)	A	A
	Magnetic field	EN 61000-4-8	30 A/m	796 A/m	A	A
Power supply V DC	Burst	EN 61000-4-4	2 kV (5/50 ns, 5 Hz)	4 kV (5/50 ns, 5 Hz)	B	A
	Surge	EN 61000-4-5	1 kV / 2 kV	1 kV / 2 kV	B	A
	Conducted RF	EN 61000-4-6	3 V/m (from 150 kHz to 80 MHz)	10 V/m (from 150 kHz to 80 MHz)	A	A
I/O signal/ control (including functional earth lines)	Burst	EN 61000-4-4	1 kV (5/50 ns, 5 kHz)	4 kV (5/50 ns, 5 kHz)	B	A
	Surge	EN 61000-4-5	1 kV	1 kV	B	A
	Conducted RF	EN 61000-4-6	3 V (from 10 kHz to 80 MHz)	10 V/m (from 150 kHz to 80 MHz)	A	A

Criteria A: Normal performances within specification limits

Criteria B: Temporary degradation or loss of performance which is self-recoverable

Criteria C: Temporary degradation or loss of performances which requires operator intervention

Performance criterion A

During testing, normal performance within the specification limits.

Example

If electronic equipment is required to work with high reliability, the EUT shall operate without any apparent degradation from the manufacturer's specification.

Performance criterion B

During testing, temporary degradation, or loss of function or performance which is selfrecovering.

Example

During testing, an analogue function value may deviate. After the test, the deviation vanishes.

Performance criterion C

During testing, temporary degradation, or loss of function or performance which requires operator intervention or system reset occurs.

Example

In the case of an interruption in the mains longer than the specified buffer time, the power supply unit of the equipment is switched off. The switch-on may be automatic or carried out by the operator.

Copy of the conformity declaration is available for download on the Gefran web site www.gefran.com

GEFRAN

GEFRAN spa

via Sebina, 74 - 25050 PROVAGLIO D'ISEO (BS) - ITALIA
tel. 0309888.1 - fax. 0309839063 Internet: <http://www.gefran.com>